

cOS Oyster-1 Outdoor Node

DISTRIBUTED ACCESS ARCHITECTURE



The Oyster is an outdoor node for distributed access architecture deployments to deliver services over PON, Ethernet or Docsis.

The Oyster node is a small form factor, temperature-hardened outdoor enclosure that supports a broad range of advanced network edge devices. Whether for fiber-to-the-home (FTTH) applications or to deliver enhanced DOCSIS services, the Oyster node integrates with Harmonic's remote switches and remote OLT modules to enable XGS-PON, 10G EPON and Ethernet, as well as Harmonic's Remote PHY (R-PHY) device supporting DOCSIS 3.1.

Oyster's versatility enables operators to easily address various deployment scenarios, including fiber deep cable deployments, as well as FTTH for multi-dwelling units (MDU) and hospitality sites, or for distributed fiber and Ethernet deployments, wireless access networks and mobile back haul for cell towers.

With a unique, cableless design the Oyster node ensures simplified deployment and maintenance. It's compact, light-weight form factor makes it easy to install on strands, in underground vaults, or on walls to easily meet space or network planning requirements.

The Oyster node is optimized to integrate with Harmonic's industry-leading cOS virtualized core software as well as additional third-party cores to offer increased space savings with distributed access architecture. To optimize power usage, the node offers unique and patented performance, vBias, to dynamically handle downstream channel load and output for optimal power consumption.

Key benefits:

- Support for R-PHY, XGS-PON, 10G EPON and Ethernet for greater optionality
- Cable and Mains powering with a universal power supply
- Patented vBias control on the RF amplifier to optimize node power consumption for optimal channel load and output performance
- Integrates with third-party R-PHY compliant CMTS Cores with Harmonic's Pebble R-PHY Device for seamless interoperability
- Small, lightweight, international compliant form factor ideal for deployment constrained by space and power
- Hot-swappable components to reduce maintenance outages
- A cableless design places all active and passive components in the base unit to eliminate cabling between the lid and base for simplified maintenance and increased performance
- Long hold-up time for high availability and resiliency to reduce service interruption caused by power outages whether from maintenance or power grid instability
- High RF output power level

HIGHLIGHTS

APPLICATIONS

- **DOCSIS** – Remote PHY,
- **PON** – Remote OLT for XGS-PON and 10G EPON
- **Ethernet** – Remote Ethernet Switch

LOCATIONS

- Indoor and Outdoor
- Wall and strand mounting
- MDU
- Cabinet

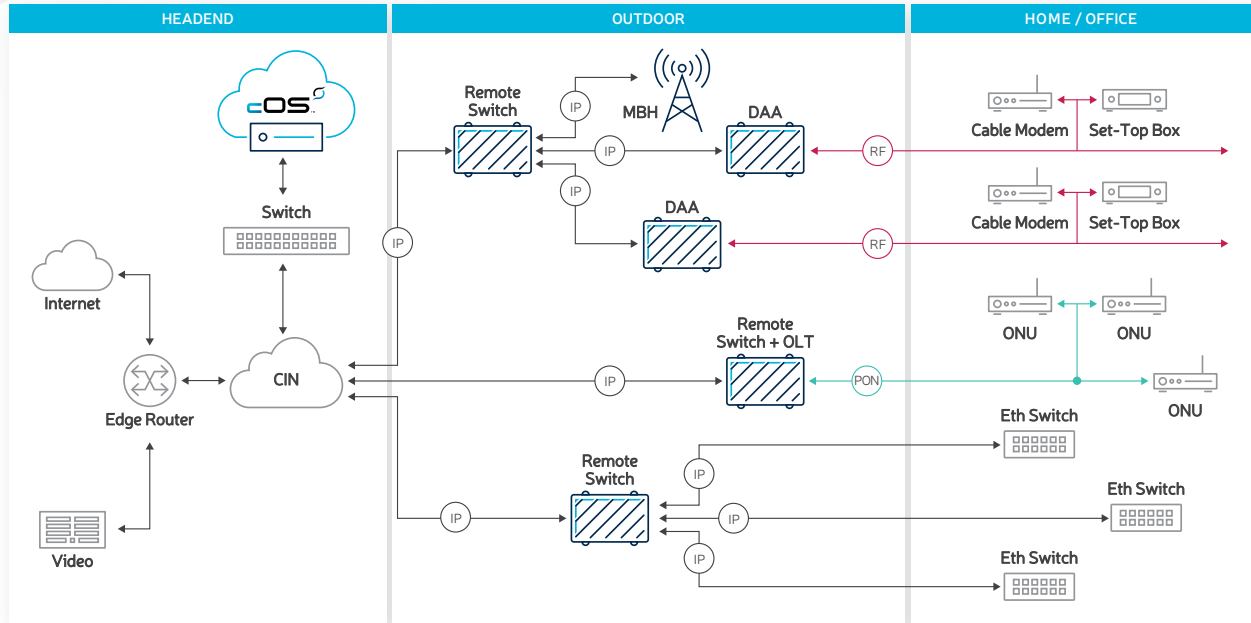

Deployment Diagram

World Class Service and Support

Harmonic's broadband solutions include cOS Central. Central offers an advanced set of online applications to provide streaming telemetry for real-time analytics and AI-driven insights with actionable recommendations to ensure optimal network and system health. Harmonic customers benefit from the company's extensive knowledge of the cable access environment and Emmy award winning product expertise.

Our teams and field engineers manage live production networks for operators of all sizes, worldwide, providing experienced technical support and guidance. With decades of collective experience in the cable industry and advanced skills our teams partner with operators to minimize service impacting events, reduce onsite interventions and to lower trouble ticket numbers by proactively accelerating issue prevention and time to resolution. The Harmonic Global Service and Support organization also understands the intricacies of every ancillary system touched by the cable access network, from back-office video control planes to IP backbones to deep-fiber HFC nodes to best support NOC teams and engineers with network planning and strategy.

SPECIFICATIONS

PHYSICAL

Mounting	Wall and Strand
Enclosure	IP67
Dimensions	230mm x 310mm x 139mm
Weight	7kg (Pebble inside)
External ports	2x for RF, 2 for AC power (cable and mains), 1 for fiber

POWER

Input Voltage Range	85VAC – 264VAC sine wave over AC Mains port or 35VAC - 95VAC quasi-square wave over AC Cable port (Same PSU supports both Mains or Cable AC power)
Hold Up Time	Typ. 1 sec for DOCSIS application Typ. 2 sec for PON and Ethernet
Flexible Power Consumption	Power consumption can be optimized for linearity requirements and output RF level
Start-Up Current	3.5A for 200msec

DOCSIS APPLICATION

Operational Bandwidth	5 -1218 MHz
Diplexers	Pluggable (42/54, 65/85, 85/102, 204/246 MHz)
RF port return loss	Typical -17dB, min. -15 dB
Test ports	Internal, one for DS, two for US ports (See diagram below)
Linear Tilt	0-14 dB, programmable
DS RF power range	12 dB, programmable

US RF power range	22 dB, programmable
Temperature Range	-40C... +60C
MER	Max 49dB, configurable
Min Input US RF Level	62 dBuV / 2 dBmV for 6.4MHz channel
Power Consumption with V-Bias Optimization:	
One Port	Max 62W for 110dBuV/ch or 50dBmV/ch, MER 45dB
Two ports	Max 67W for 110dBuV/ch or 50dBmV/ch, MER 45dB
Power Consumption without V-Bias optimization:	Max 72W

DS RF POWER LEVEL

One RF Port (1x1x1) Model	
Output RF TCP Level, max	133.8 dBuV / 73.8 dBmV
Output RF Channel Level, max	117 dBuV @ 8MHz, 10dB tilt from 258 to 1218MHz (55.5 dBmV @ 6MHz, 10dB tilt from 258 to 1218MHz)
Two RF Ports (1x2x2) Model	
Output RF TCP Level, max	130 dBuV / 70 dBmV
Output RF Channel Level, max	113 dBuV @ 8MHz, 10dB tilt from 258 to 1218MHz (51.5 dBmV @ 6MHz, 10dB tilt from 258 to 1218MHz)

FIBER AND ETHERNET APPLICATION

<p>Oyster can support one Jetty-1 remote switch offering six 10Gb ports. Five of the Jetty-1 ports support Harmonic's Fin-1 OLT module for XGS-PON and 10GE-PON. For more detailed specifications, see Jetty-1 and Fin-1 data sheet.</p>	
Temperature range	-40C...+60C
Power Consumption	40W max, fully loaded with 1x SFP+ and 5x Fin-1 R-OLT

One RF Port (1x1x1) Model Diagram

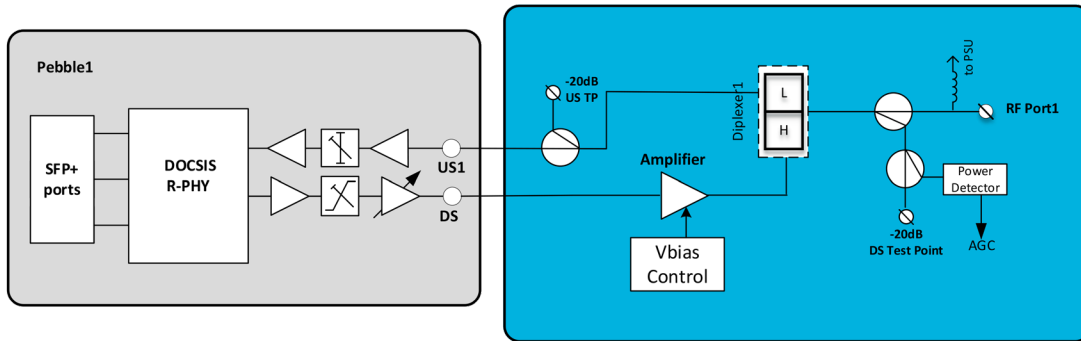

Two RF Ports (1x2x2) Model Diagram

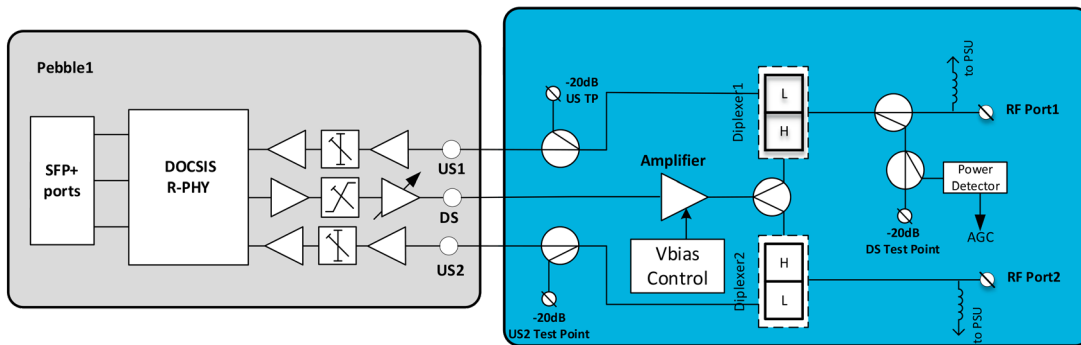

ORDERING INFORMATION

Model P/N	Description
COS-OYS-PON-NN-NN-NN-U-GN-NN	OYSTER NODE BUNDLE, PON BOARD, UNIVERSAL PS, GN ACCESS
COS-OYS-D31-HP-NN-1X2-U-AM-NN	OYSTER NODE BUNDLE, HIGH POWER RFB, NO-SPLIT, FOR PEBBLE OYSTER 1X2, UNIVERSAL PS, AM ACCESS.
COS-OYS-D31-HP-NN-1X1-U-RW-NN	OYSTER NODE BUNDLE, HIGH POWER RFB, NO-SPLIT, FOR PEBBLE OYSTER 1X1, UNIVERSAL PS, RW/EU ACCESS.
COS-OYS-D31-HP-NN-1X2-U-RW-NN	OYSTER NODE BUNDLE, HIGH POWER RFB, NO-SPLIT, FOR PEBBLE OYSTER 1X2, UNIVERSAL PS, RW/EU ACCESS.